

Dean Pump® Chemical Process Industrial Inline Pumps

**DeanLine
Series**



DeanLine Series

Dean Pump® DeanLine Series Chemical Process Industrial Inline Pumps

- Capacities to 95 GPM (22m³/hr)
- Heads to 130 Feet (39 m)
- Pumping Temperatures to 220°F (104°C)
- Working Pressures to 100 PSIG (689 kPa)
- Two Sizes

DeanLine Series Pumps offer inline pump convenience for simple installations. They are excellent for process plant pump applications for capacities and heads less than ANSI AA and AB sizes. Standard features include an open impeller with integral seal and an electric driven motor. An optional air driven motor is also available. Two pump sizes are available in cast iron and 316SS construction. Special features include:

- Factory testing for operating performance and hydrostatic testing for casting soundness
- Standard shaft extension to eliminate alignment problems, no coupling needed

Applications

- Transfer Service
- Hospital Service
 - Lime Water Circulation
 - Water Circulation—Kidney Dialysis
- Condensate Service
- Line Boosters
- Soft Slurries
- Paper Coating
- Plating Solutions
- Heat Transfer Liquids
- Bottle Wash Systems
- Loading Pumps
- Tank Car Unloading
- System Cleaning Solutions
- Pilot Plant Applications
- Starch Slurries
- Dye Liquors
- Distilleries
- Aquarium Water Circulation
- Solvent Recovery Systems

Liquids Handled Include:

- 15% Acetic Acid & Water
- Alcohol
- Alcohol & Water
- Binder Solution
- Boron Trifluoride
- Brandy
- Brine
- 14 Butate Diol
- Condensate
- Cordials
- Cyanide Rinse
- Deionized Water
- Dimethylamine
- 200°F Dowtherm*
- EDC Reflux
- Epichlorohydrin
- Fatty Alcohol
- Freon II
- Formaldehyde
- JP4 Fuel
- Gasoline
- Glycol
- Heat Transfer Oil
- Hexachlorophene
- Hexane
- Hot Water
- Hot Wax
- Hydro Carbons and Dissolved H₂S
- Hydrogen Sulfide
- Kerosene
- Light Oil
- Lime Water
- Methanol
- Mineral Oil
- 7% NA Carbonate Solution
- Pentachlorophenol
- Perchloro-ethylene
- 205°F Polystyrene
- Quench Oil
- Slurries
- Sodium Hydroxide
- Sodium Nitrate
- Soluble Paint and Water
- Solvents
- Sour Water
- Sulfuric, Concentrated
- Tetrachlorethane
- Thinners
- Trichlorobenzene
- Turpentine
- Vegetable Oil
- Vinegar
- Xylene
- Zinc Hydro Sulfate



*Dow Chemical Co.

1 1/2" DL Performance – Electric Motor

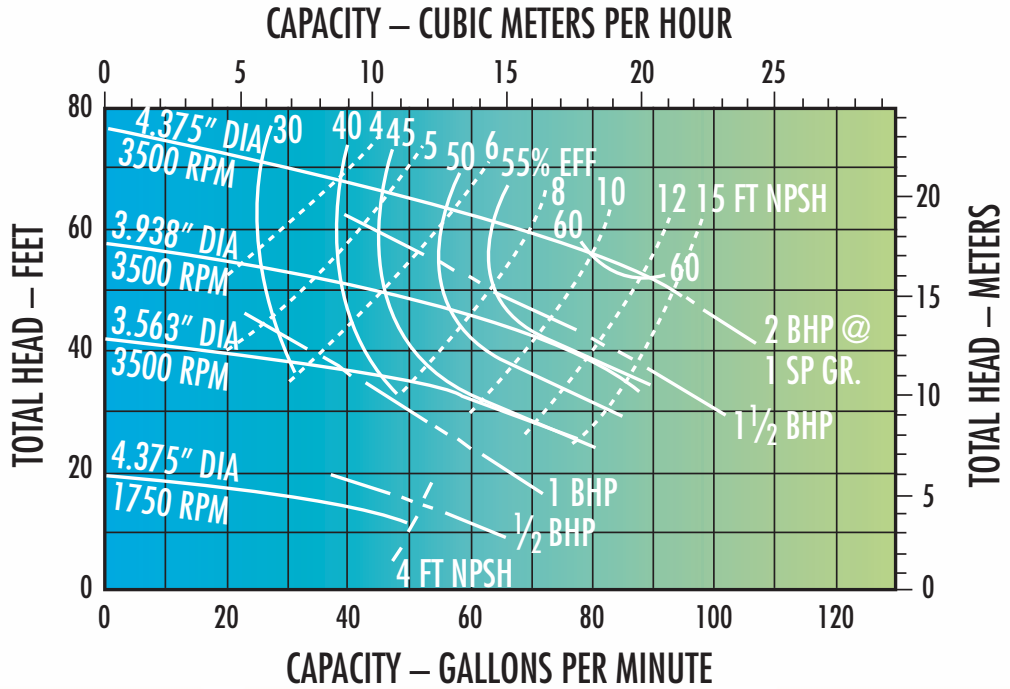

3/4" DL Performance – Electric Motor

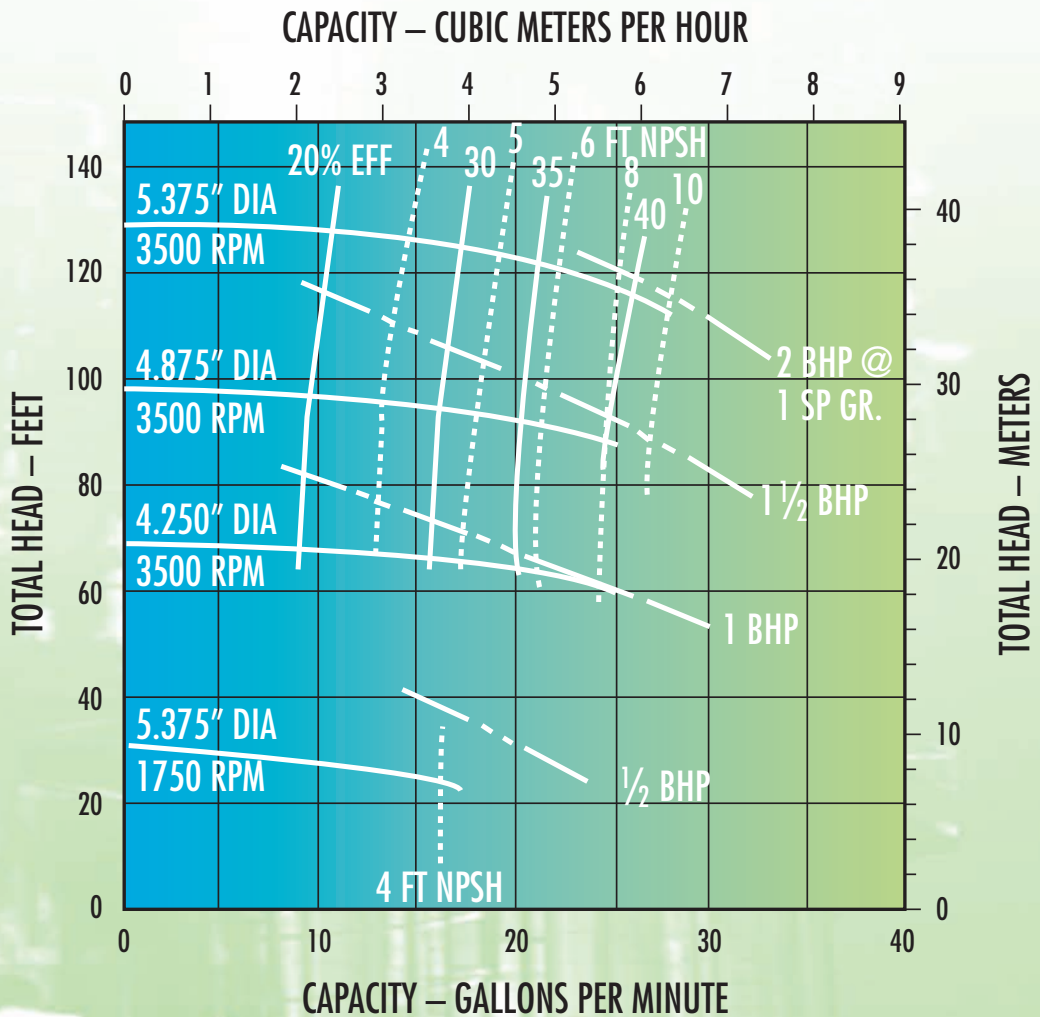

Air Motor



1 1/2" DL Performance – Air Motor

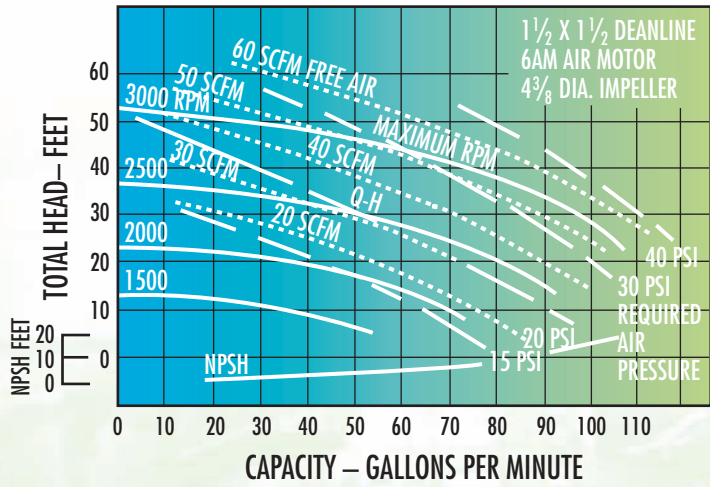

3/4" DL Performance – Air Motor

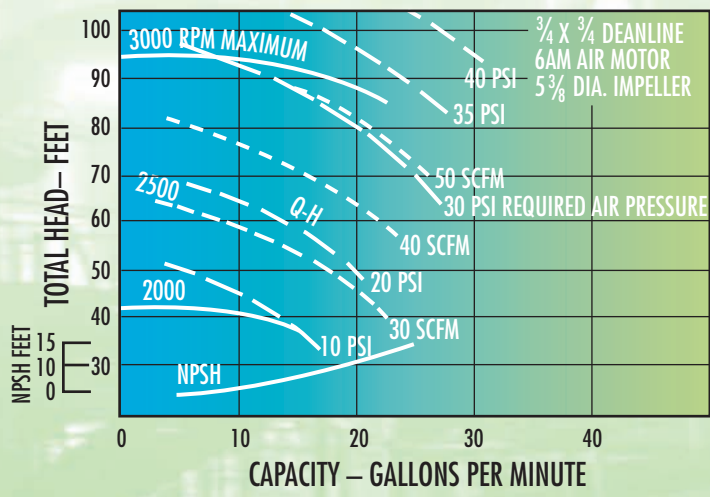

Options

Motor: For hazardous duty, an air motor can deliver up to 10 gpm at 96 ft. of head with 35 psi air pressure. A turn of the pressure regulator adjusts the pump speed to match needs. The motor can deliver 4 hp at 3000 rpm with 100 psi air pressure at the inlet.

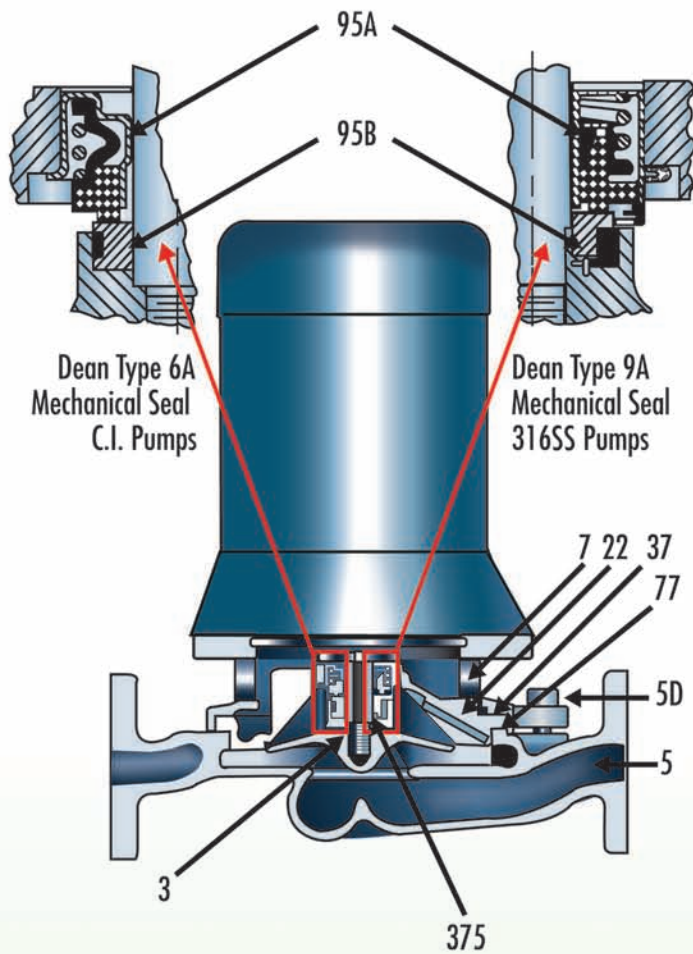

MECHANICAL DESIGN SPECIFICATIONS	
Direction of Rotation (Viewed from Motor End)	Clockwise
Driver Rating	230/460 Volt, 3 Phase, 60 Cycle, NEMA C Flange, 143TCZ Frame, Dean Standard Motors, 304SS Shaft with standard shaft extension for jet motor, NEMA T3B temperature rating for Ex. Pr. motors, which are Class I, Troup D; Class II, Groups F&G.
Horsepower Rating @ 1750 RPM @ 3500 RPM	1/2 HP 1, 1 1/2 and 2 HP
Flanges A.N.S.I. Rating	Class 125 C.I., Class 150 316SS
Impeller	Single Plane Spin Balance
Maximum Working Pressure	100 PSIG
Maximum Suction Pressure	Any Part of Working Pressure
Hydrostatic Test Pressure	150 PSIG C.I. and 200 PSIG 316SS
Pumping Temperature Minimum Maximum	Minus 20°F C.I. and 316SS 220°F C.I. and 316SS
Stuffing Box	Integral Mechanical Seal Only, Internal Seal Face Flushing All Pumps
Corrosion Allowance	1/8 inch

STANDARD MATERIALS OF CONSTRUCTION			
Part	Part No.	Iron (Class 20)	316SS (Class 50)
Impeller	3	C.I.	316SS
Casing	5	C.I.	316SS
Casing Cap Screw	5D	ASTM A307 Steel	
Adapter Cradle	7	C.I.	
Adapter Cap Screw	7G	ASTM A307 Steel	
Casing Back Cover	22	C.I.	316SS
Clearance Shim	37	Plastic	
Casing Gasket	77	Aramid Fiber	
Stationary Seal Element Stationary Face Spring Holder Shaft Packing	95A	Carbon 304SS Viton	Carbon 316SS 316SS Teflon
Rotating Seal Face	95B	Ceramic	
Seal Dowel Pin	375	Not Required	316SS

MECHANICAL SEAL SPECIFICATIONS					
Pump Material Class	Mechanical Seal	Suction Pressure Max	Suction Pressure Min.	Temperature Max	Temperature Min.
20 or 50	Dean Type 6A, 6C or 9A	100 PSIG	2 PSIA	220°F	-20°F

Options

External Flush: When specified, the seal chamber can be supplied with an external flush instead of the standard internal flush.

Seal Chamber: In addition to our standard seals, the 6C seal is available for caustic service. It is composed of 304SS metal parts, high aluminum ceramic vs. carbon mating faces, and a viton bellows.

Dimensions

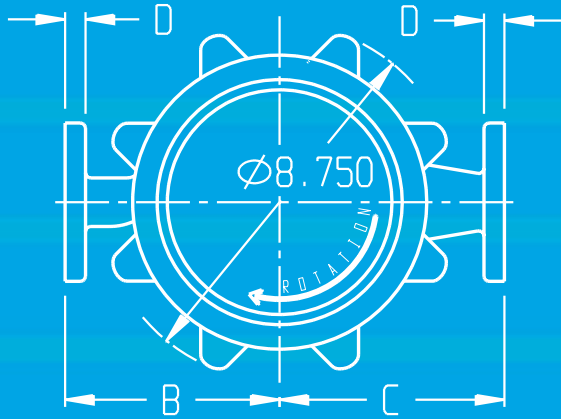

DIMENSION #	3/4" DL	1 1/2" DL
A	10.750	11.000
B	5.250	5.500
C	5.500	5.500
D	0.500	0.688
E	3.875 O.D., FOUR 0.563" HOLES ON 2.750" DIA. B.C.	5.00" O.D., FOUR 0.625" HOLES ON 3.875" DIA. B.C.

CP		
HP	TEFC	EXPR
1/2	14.00	15.00
C	14.00	15.00
1 1/2	14.00	15.50
2	14.00	16.50

All dimensions are in inches.

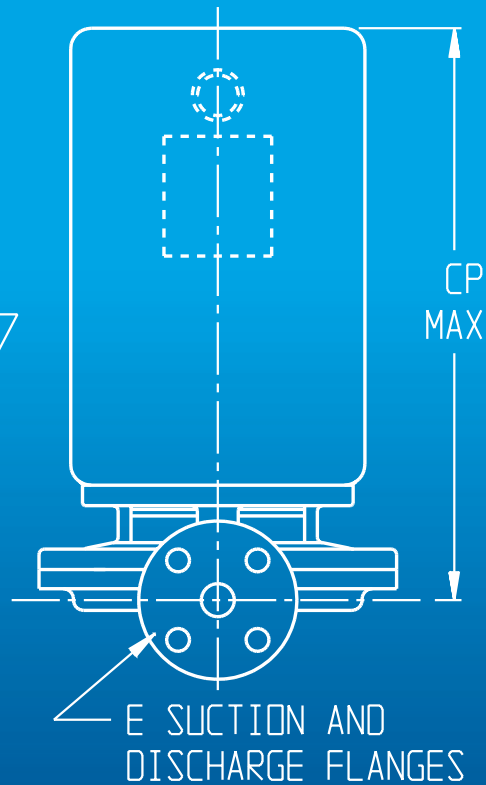
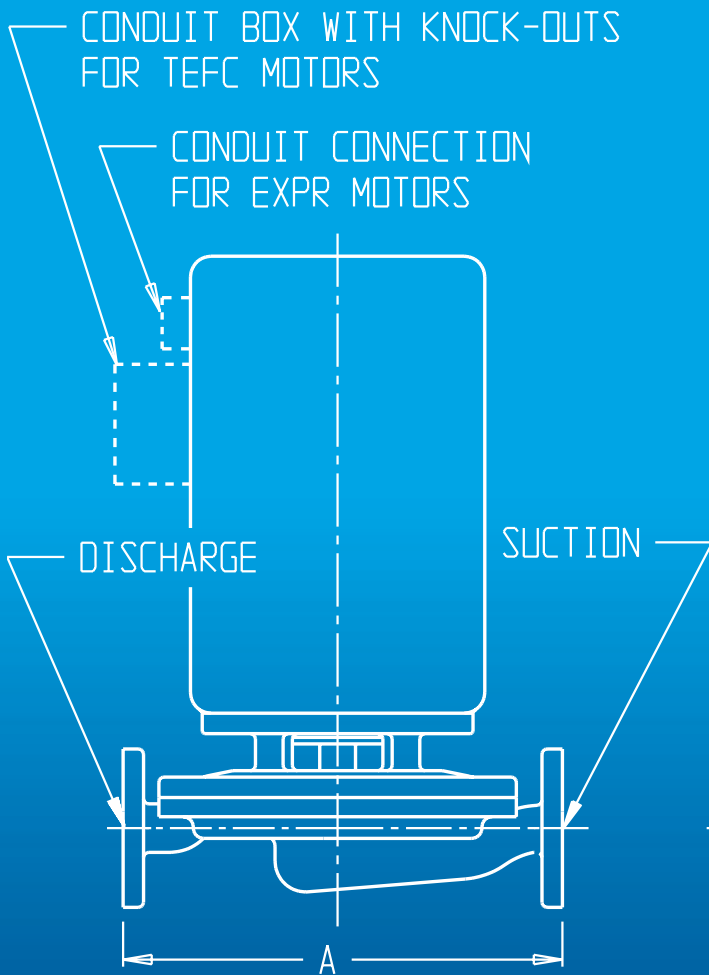

A Met-Pro Fluid Handling Technologies Business
Combining the Resources of Dean Pump, Fybroc & Sether

6040 Guion Road • Indianapolis, IN 46254
P: 317.293.2930 • TOLL-FREE: 800.801.9265 • F: 317.297.7028
info@deanpump.com • www.deanpump.com



© 2010 MET-PRO CORPORATION
DEAN PUMP® IS A REGISTERED TRADEMARK OF MET-PRO CORPORATION 09-5932 810